

# PUSH BACK SYSTEM



## Advantages of the Push Back System



Push-back is an accumulative storage system that allows you to store up to four pallets deep per level.

All of the pallets on each level, except the last, are placed on a set of trolleys that are pushed along the rolling rails. These rails are built on a slight incline, lower at the front, so that the pallets at the back move forward when the pallet closest to the aisle is removed.

All the pallets placed on a particular level must contain the same SKU and are managed using the Last In First Out (or LIFO) system.



# Advantages of the Push Back System

## Advantages of this system:

- The fact that this is a compact storage unit means that the best possible use is made of the space available. Compared to the conventional system, Push-back pallet racking provides considerably more storage capacity.
- Ideal for storing medium turnover products, with two or more pallets per SKU.
- The specially designed system means that very little height space is wasted.
- Unlike other compact systems, each level can be used to store a different SKU.
- The pallet centralisers, stops and blocking devices make loading and unloading operations safer and easier.
- The system can be easily installed and modified according to particular requirements.



## Comparison between the space occupied by a conventional system and a Push-back system



Calculation made using a pallet measuring 1,200 x 1,200 mm.

# Push Back System

## Handling pallets with a fork-lift

Unlike the conventional system, with Push-back, the fork-lift handles pallets with the stringers placed perpendicularly, in such a way that they rest cross-ways on the trolleys and rails.

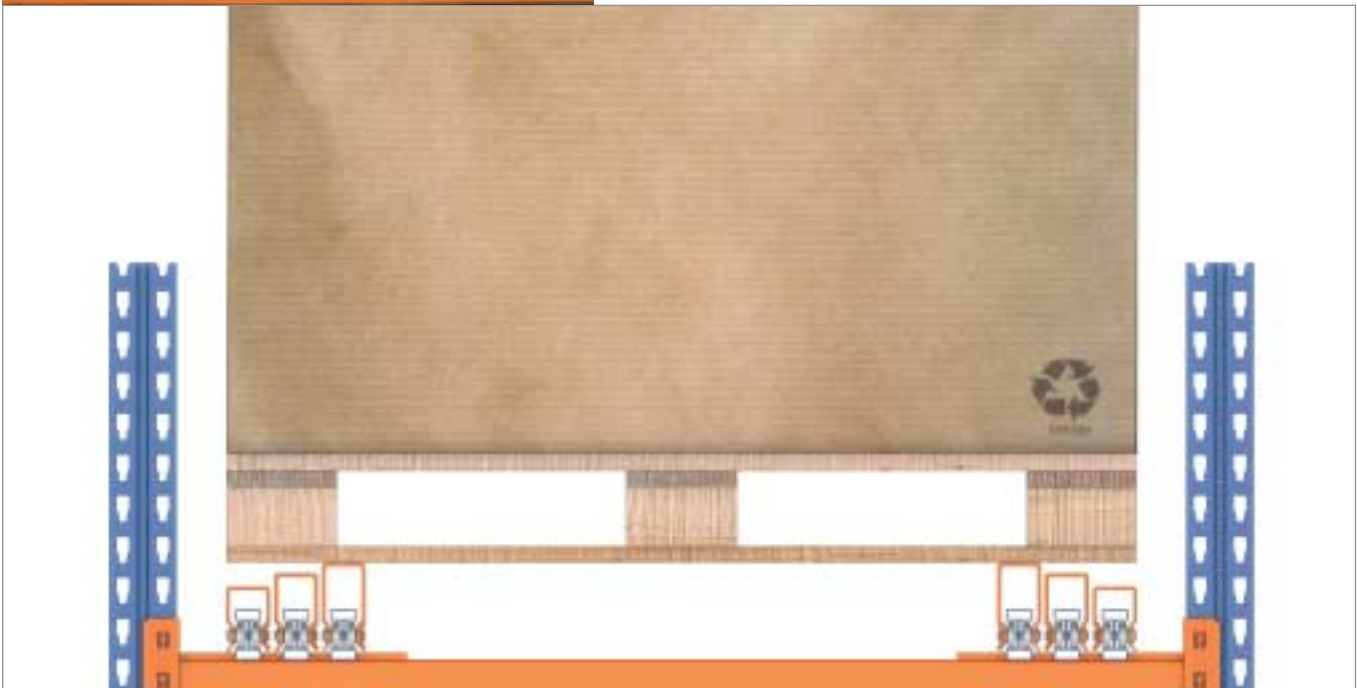

# Push Back System

The system operates very simply:

- Each level of racking includes two or three parallel trolleys at different heights.
- The fork-lift places the first pallet on the highest set of parallel trolleys.
- When loading the second pallet, the fork-lift pushes the first one along until it reaches the next set of trolleys, and deposits the pallet on these.
- If the installation has been designed to store four pallets, the operation is repeated with the third pallet and the last one is rested directly on the rolling rails, rather than on the trolleys.
- When unloading pallets, the modus operandi is reversed, in such a way that when the first pallet is removed, the others move forward one place towards the aisle.



# Components of the Push Back System

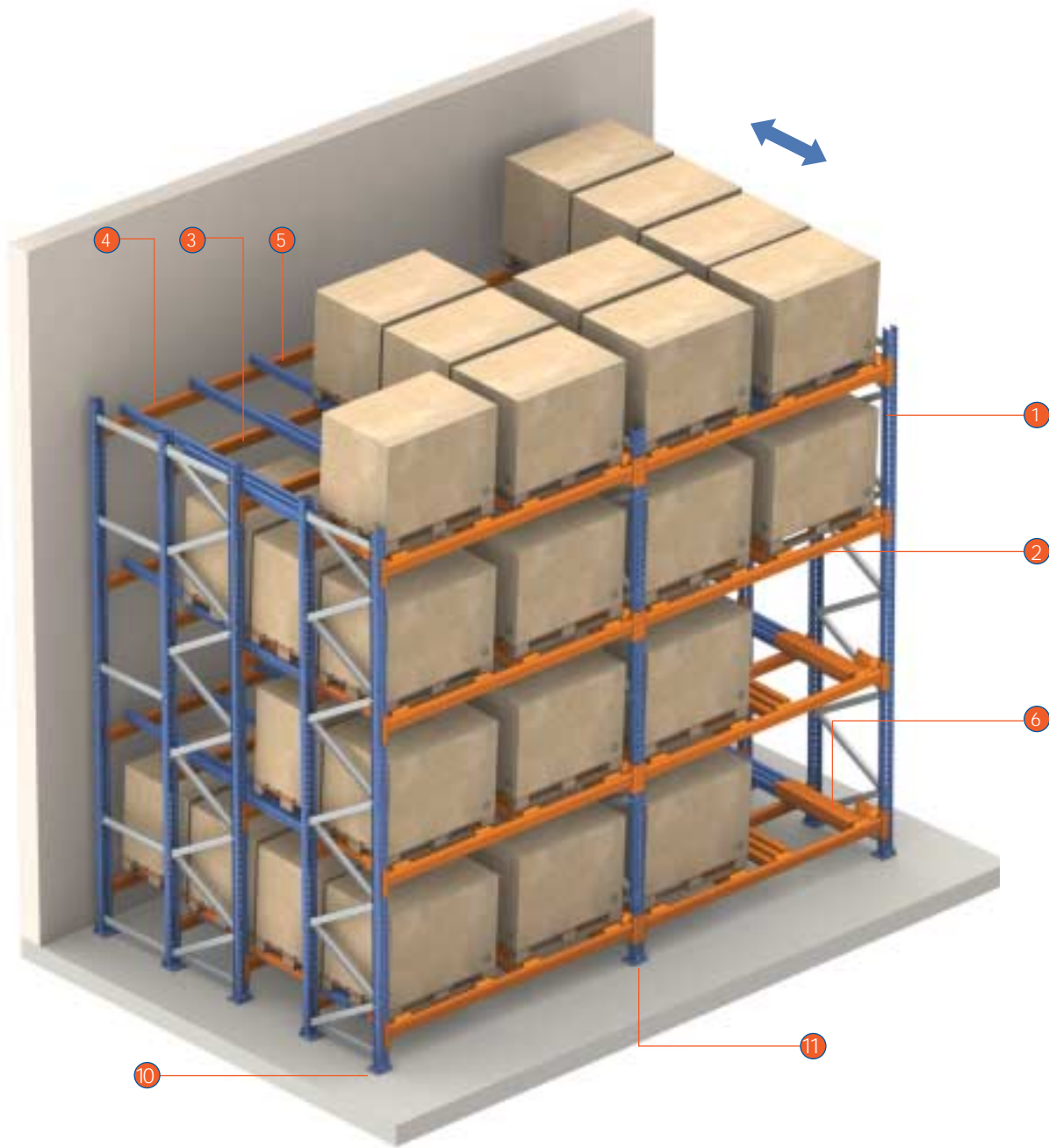

## Elementos básicos de las estanterías para Push-back

- |                   |                     |                     |
|-------------------|---------------------|---------------------|
| 1 Frame           | 5 Rails             | 9 Trolley control   |
| 2 PB front beams  | 6 PB trolleys       | 10 Levelling plates |
| 3 PB middle beams | 7 PB rail supports  | 11 Anchors          |
| 4 PB top beams    | 8 PB safety devices |                     |

# Components of the Push Back System

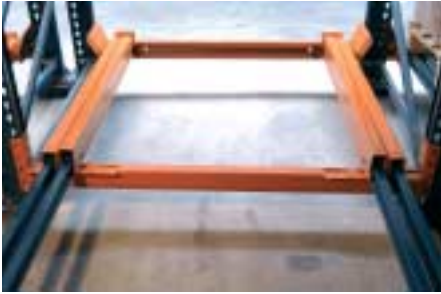

Both the rolling rails and the trolleys rest on the racking beams. These are assembled with the necessary slope so that the trolleys will move correctly.



The levels are built to house one or two storage channels.



In addition to the rolling elements, each trolley also has a safety bolt that prevents it from moving if the pallet has not been placed correctly.



The fact that the rail is I shaped means that the rolling elements slot over both sides of the central beam, thus ensuring correct movement and preventing any possibility of derailment.



5

7



There are centralisers on both sides of each channel to centre the pallet. These help to place it in the correct position with the stops of the front beam.



9

The front beams have support and fixing elements, as well as stops and holes, allowing a small piece of the available trolley to stick out. This is particularly important for high levels.

# Push Back System Adaptations

The system can be adapted to store two, three or four pallets deep.

Once the model and measurements of the pallets have been analysed, together with the available space and the type of forklift to be used, the number of pallets can be specified.

The construction system is similar in all cases. The only things that change are the number and measurements of the trolleys and rails.

## Assembly for two pallets deep

This assembly has only two rails and two parallel trolleys. The first pallet rests on the trolleys and the second rests directly on the rails.

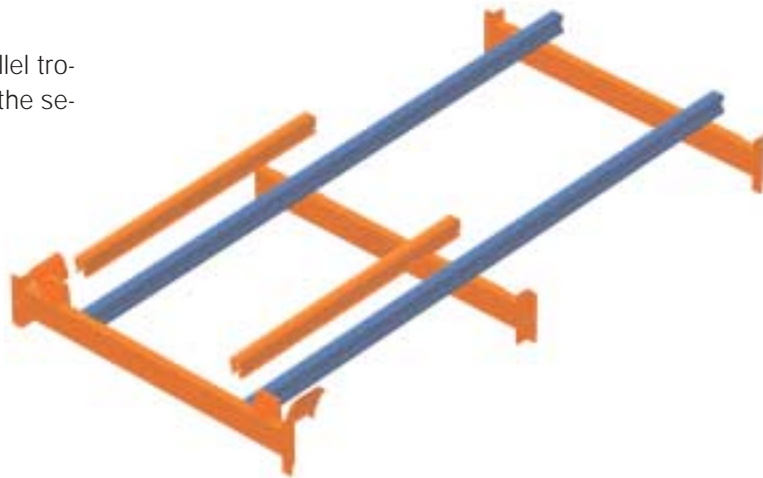

## Assembly for three pallets deep

This system incorporates four rails and four trolleys (two of the rails are shorter than the others.) The first and second pallets rest on the trolleys and the third rests directly on the rails.

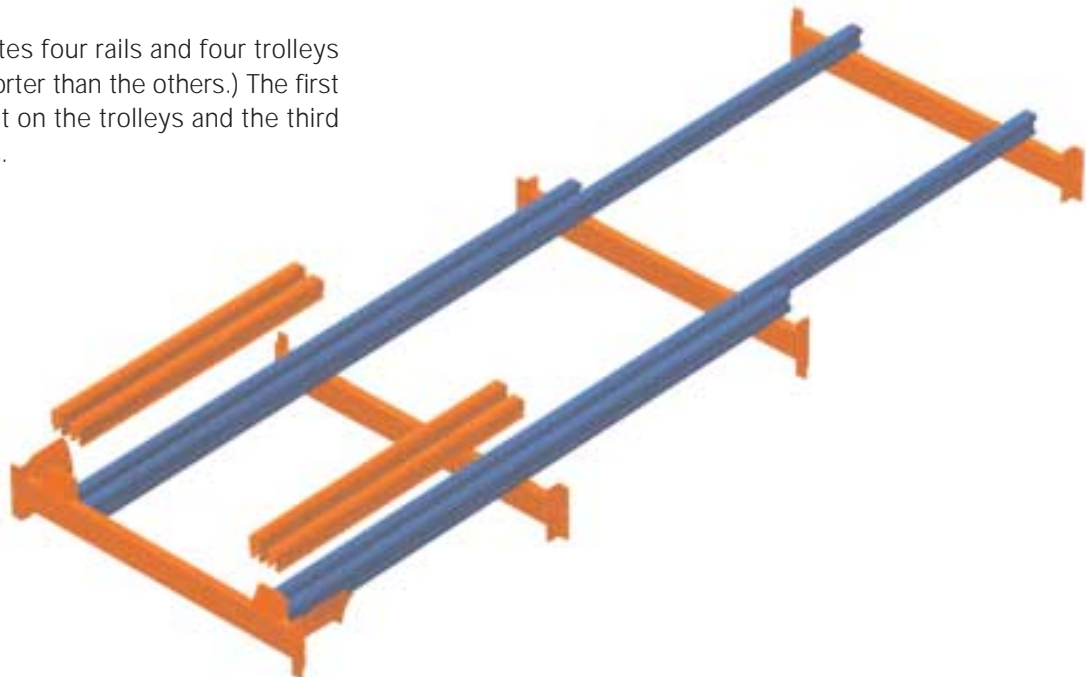

## Push Back System Adaptations

### Assembly for four pallets deep

This assembly has six rails of three different measurements and six trolleys. The first, second and third pallets rest on the trolleys and the fourth rests directly on the rails.

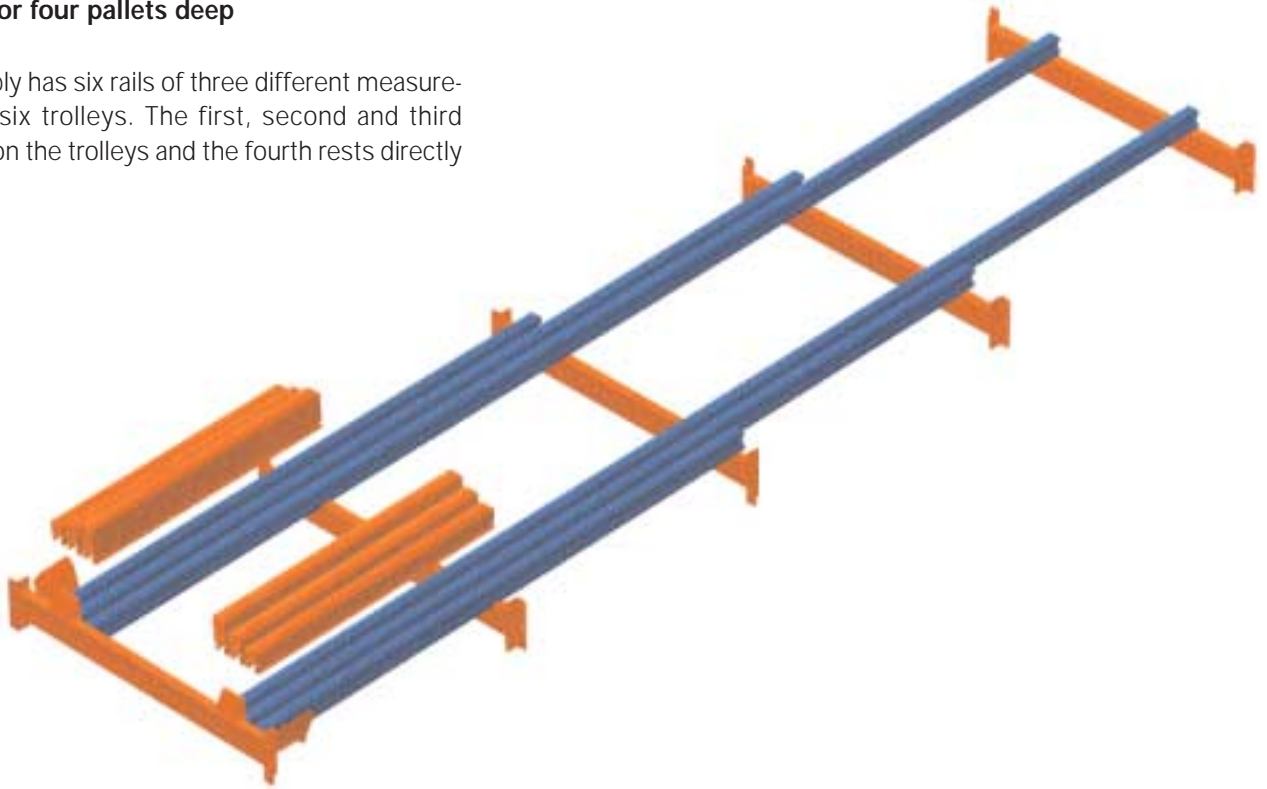

## Push Back System on Rollers

Another variation of the trolley system is the system made up of roller channels. This works in a similar way to the trolley system, but rollers take the place of rails and trolleys.

The construction system is the same as that used for the live storage system, but the pallets are put in and taken out from the same side.

With this system, the narrow side of the pallets is the side that is handled, so that the stringers of the pallets rest perpendicularly on the rollers, thus facilitating movement.

Given that the channels slope slightly, when the first pallet is removed, the rest move forward one position.

In order to choose the most suitable system, an analysis should be made of each customer's needs regarding capacity, number of SKU's and operating system.

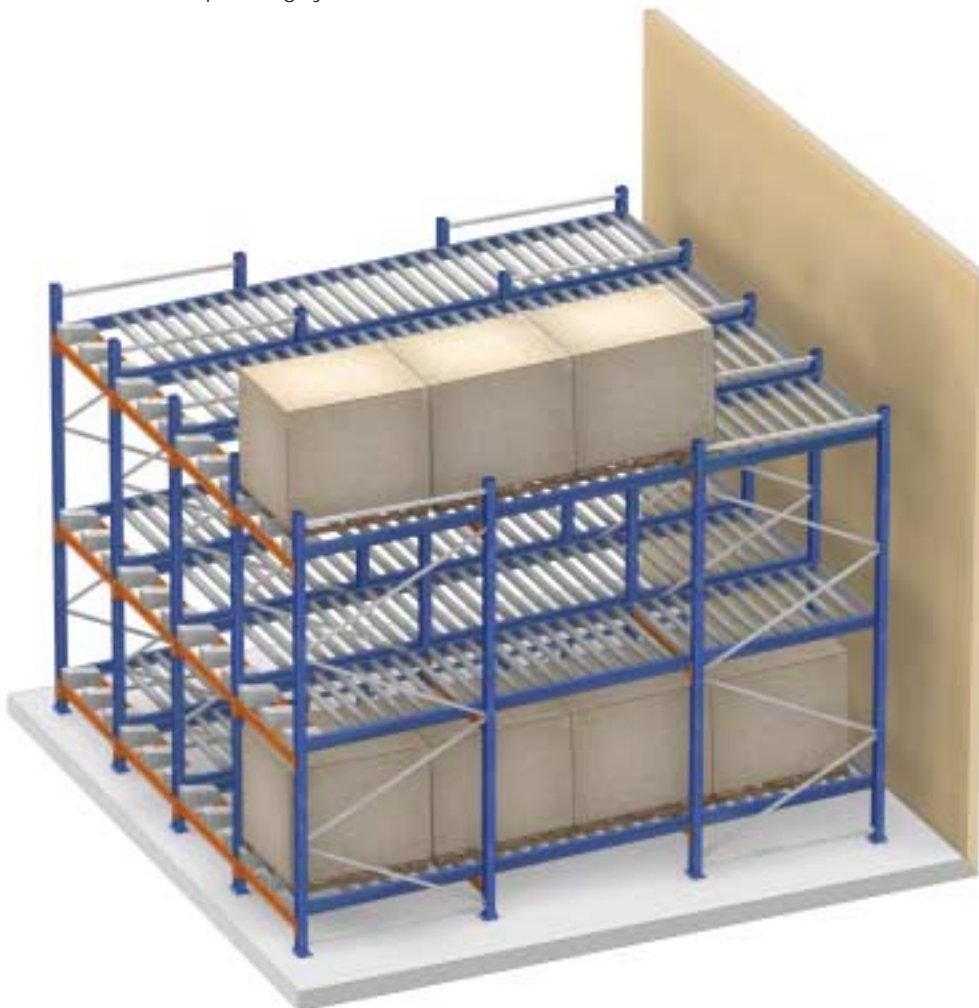
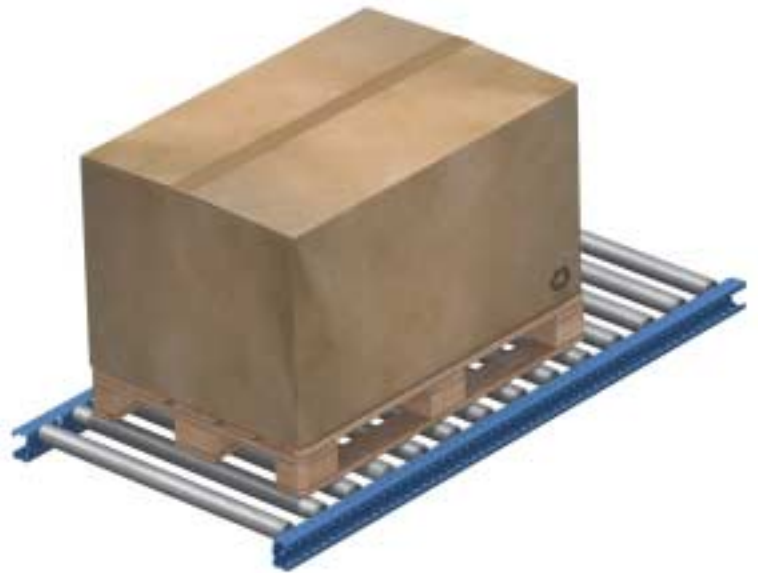

# Push Back System on Rollers

