

# STRUCTURAL CANTILEVER

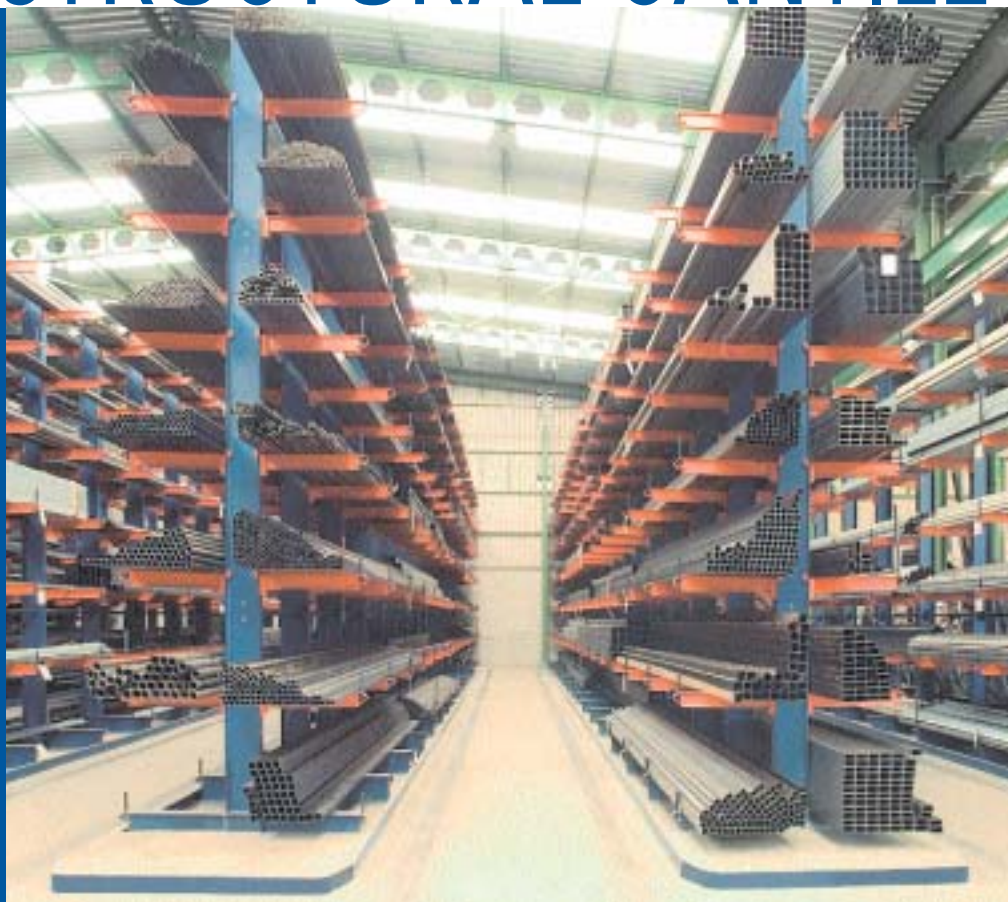

## Cantilever Racking



### Cantilever Racking

Cantilever racking is specially designed to store long or varying length items, such as metal beams, pipes, molding, wooden boards, metal and plastic sheets among other materials.

The system basically consists of columns with one or two horizontal beams at the base to provide stability. A series of arms are attached on which the load is placed.

Loads may be handled manually when they are lightweight, or by using lift trucks or other appropriate lifting systems when heavy items are involved.

### Single and Double sided versions

The warehouse is laid out with a combination of single sided Cantilever, normally placed against the walls with access from one side only. Double sided Cantilever can be used as an alternative which allows access from both sides.

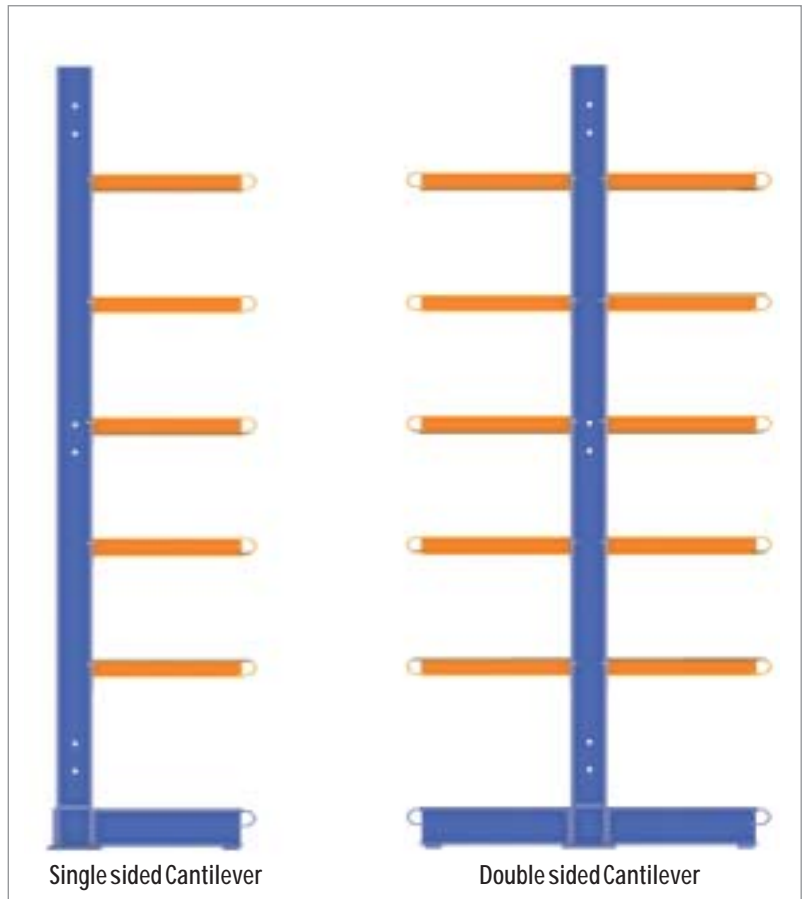

## Construction Systems

Mecalux has developed a range of two Cantilever racking systems to cover all market needs: medium and heavy duty.

The choice of the most appropriate system depends on the characteristics of the product to be stored, in particular the weight, size and the height.



### Medium Duty Cantilever

This system has been developed for storing lighter loads. All the elements involved fit together easily.

This system is made of beams appropriate for mechanically handled medium-weight loads.



### Heavy Duty Cantilever

This is a system, with a high-load bearing capacity for goods handled using lift trucks, mobile cranes, stacker cranes, and other such machinery.

It is easily assembled, with interlocking parts that provide excellent mobility. This means that the system can be adapted to any possible future needs.

# Cantilever Racking

## Medium Duty Cantilever

This system is made of hot-rolled steel profiles at heights of 8'-14'. It is designed to support medium loads.

The parts are designed to allow the levels to be assembled quickly and easily.

The holes in the columns and the arm attachment system means the distribution of shelves can be changed easily.

### Basic Components

- 1) CTVMcolumns
- 2) CTVMbases
- 3) CTVMarms
- 4) Armstops
- 5) CTVMHcolumnjoints
- 6) CTVMHcrossbracing
- 7) CTVMshims
- 8) Anchoringplates
- 9) Safetyin

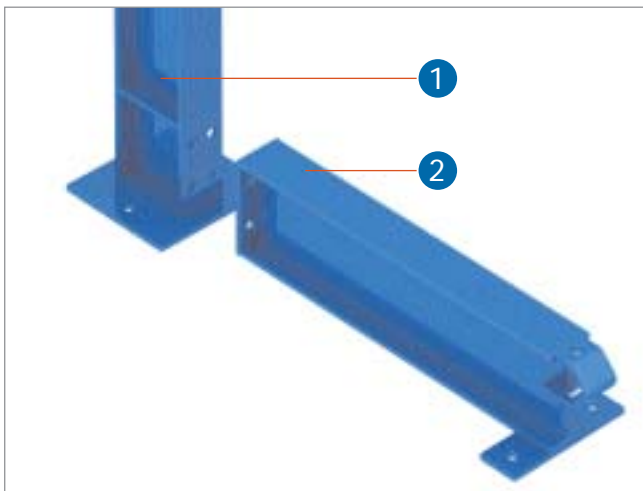
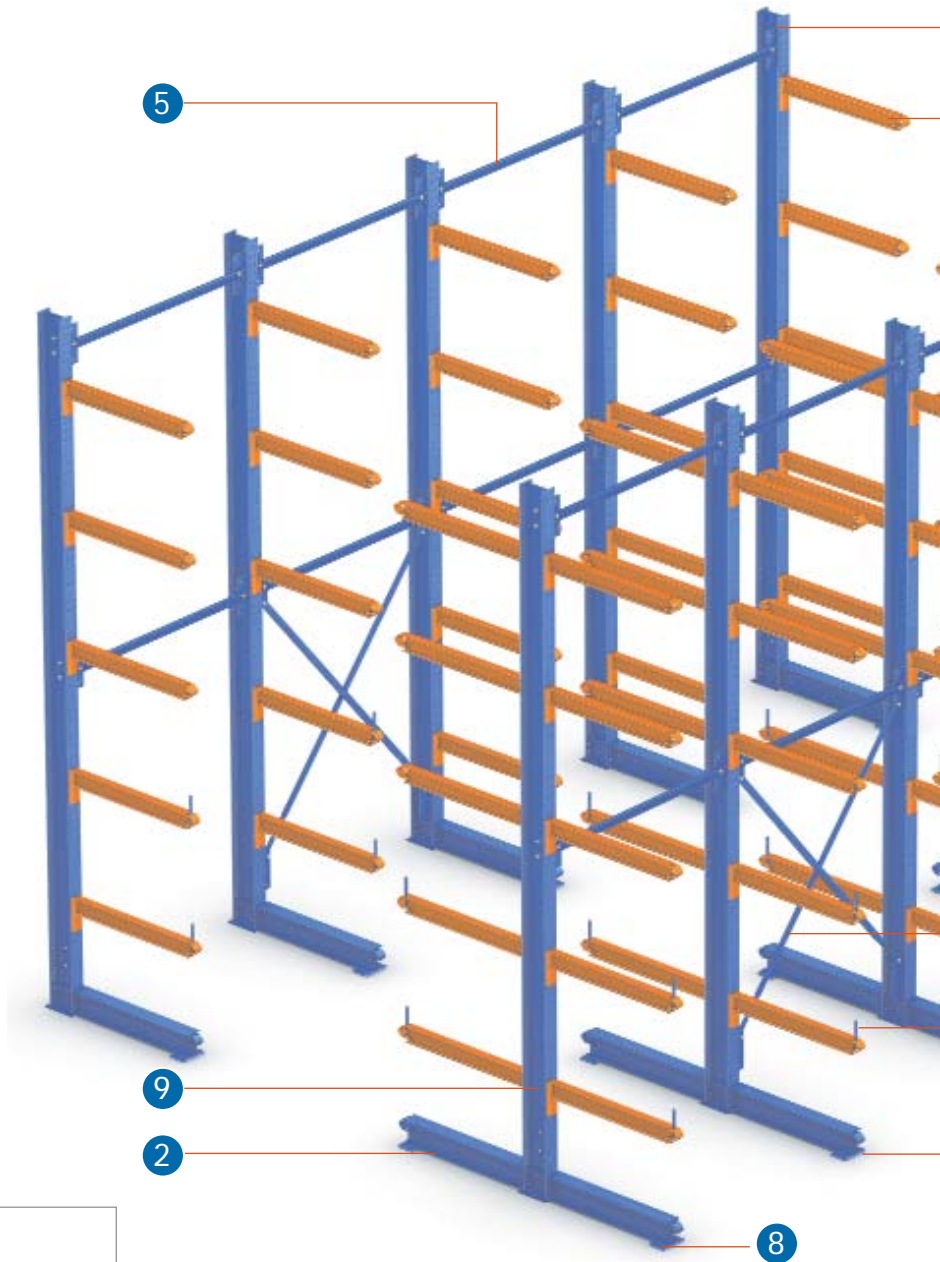

### BaseDetail

The base is bolted to the column by means of an attachment plate.

At the other end, the stop attachment parts facilitate placement of the loads.

The plates are ready for anchoring to the floor.

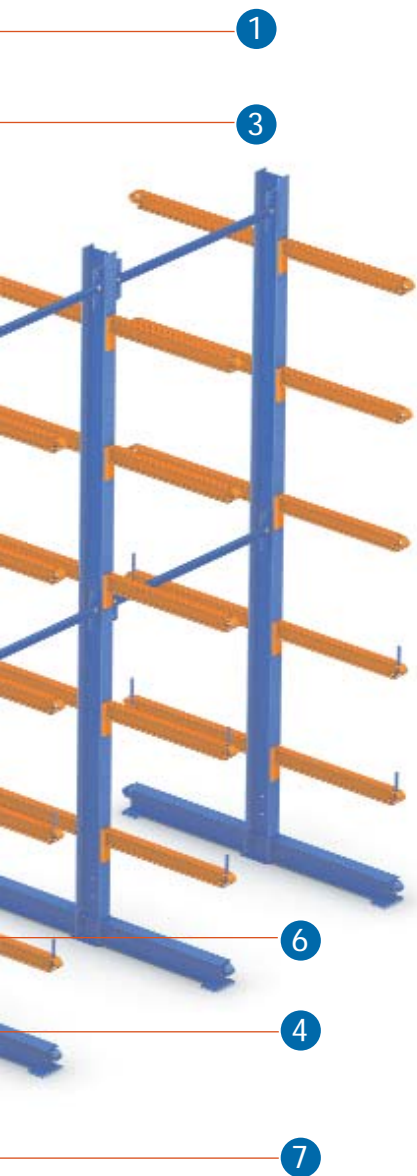

### Columns

These are manufactured from W6" x 9 bolted or W6" x12 bolted.

The positioning of the slots means the arms can be placed at intervals of 2-5/8" .

The core has attachment points for joints and cross bracing.

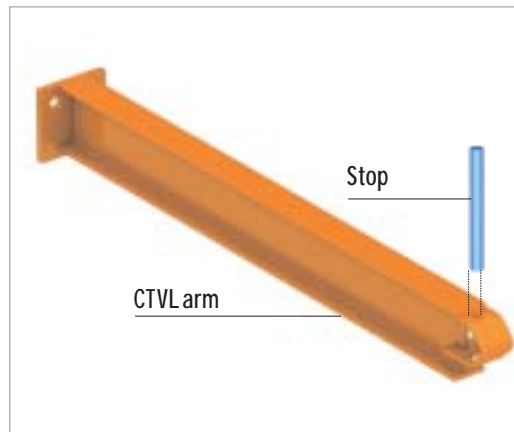

### Arms

These are manufactured from S3" x5.7 beams with a plate welded to one end for bolting into the holes on the columns. At the opposite end, a curved part facilitates placement of the loads.

The stops are optional and are inserted in the top hole, while slotting into the bottom hook at the same time.

Once assembled, the arms slope slightly towards the column in order to provide extra safety.



### Cross Bracing

Cross Bracing with tension bolts and column joints connect columns together along the length of the system for rigidity purposes thus providing a solid stable structure.

# Cantilever Racking

## Medium Duty Cantilever

### Column Load-bearing Capacity with arms of 3" x 5,7

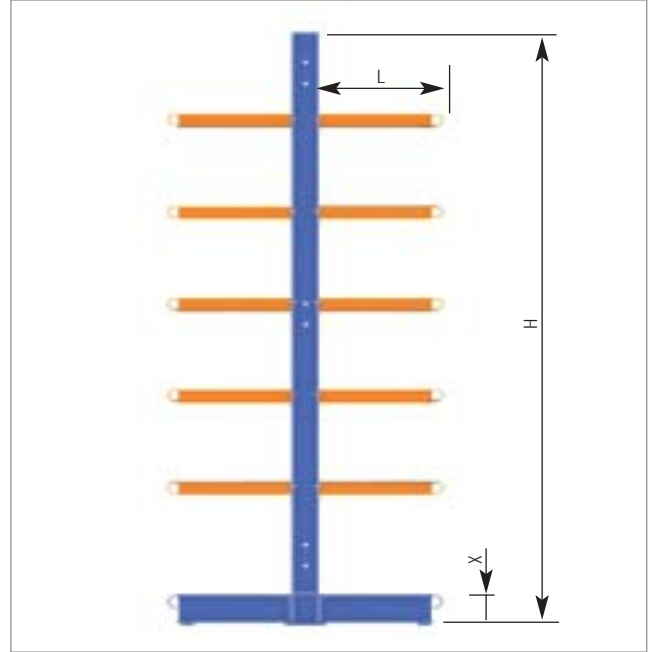
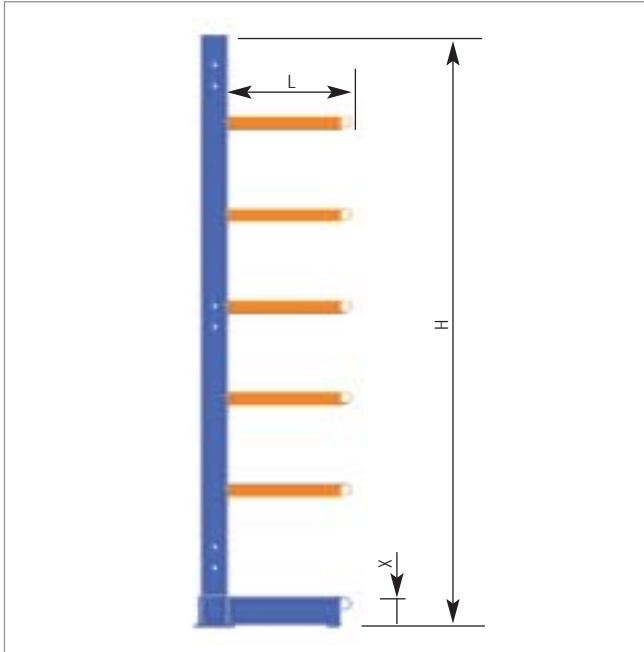

#### CAPACITY PER COLUMN (lbs)

H= Column (ft)	L=Arm (inch)	SINGLE SIDE		DOUBLE SIDE	
		W6"x9	W6"x12	W6"x9	W6"x12
8	14	12164	13092	24328	26184
	20	9856	10040	19712	20080
	24	8625	8680	17250	17360
	30	7256	7200	14512	14400
	36	6240	6136	12480	12272
	40	5778	5576	11556	11152
10	14	11505	13080	23010	26160
	20	9335	10025	18670	20050
	24	8195	8660	16390	17320
	30	6885	7170	13770	14340
	36	5915	6100	11830	12200
	40	5400	5540	10800	11080
12	14	10521	13055	21042	26110
	20	8015	9989	16030	19978
	24	6895	8617	13790	17234
	30	5670	7119	11340	14238
	36	4781	6041	9562	12082
	40	4312	5467	8624	10934
14	14	9052	12606	18104	25212
	20	71761	9642	14352	19284
	24	6174	8316	12348	16632
	30	5082	6870	10164	13740
	36	4176	5826	8352	11652
	40	3880	5274	7760	10548

The load is given in lbs.

The load varies according to the number of arms and their layout.

The load calculated for the central columns is the sum of the two sides (50% per side).

## Arm Load-bearing Capacity

### CAPACITY (lbs) FOR STRUCTURAL CANTILEVER ARMS

L=Arm (inch)	Column	
	W6"x9	W6"x12
14"	2281	2444
20"	1593	1708
24"	1326	1421
30"	1057	1133
36"	877	941
40"	787	844

The evenly distributed load is calculated in lbs.

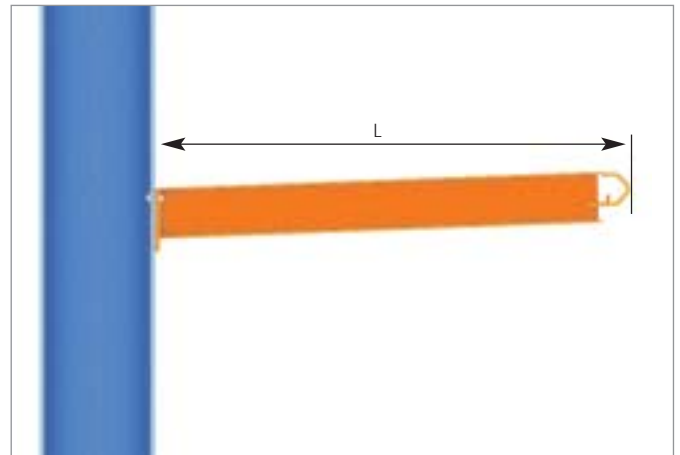

## Heavy Duty Cantilever

This is a similar system to the medium Cantilever, but with larger beams and arms and with 3-7/8" intervals for attaching individual arms.

The different components have been developed to withstand the heaviest loads.

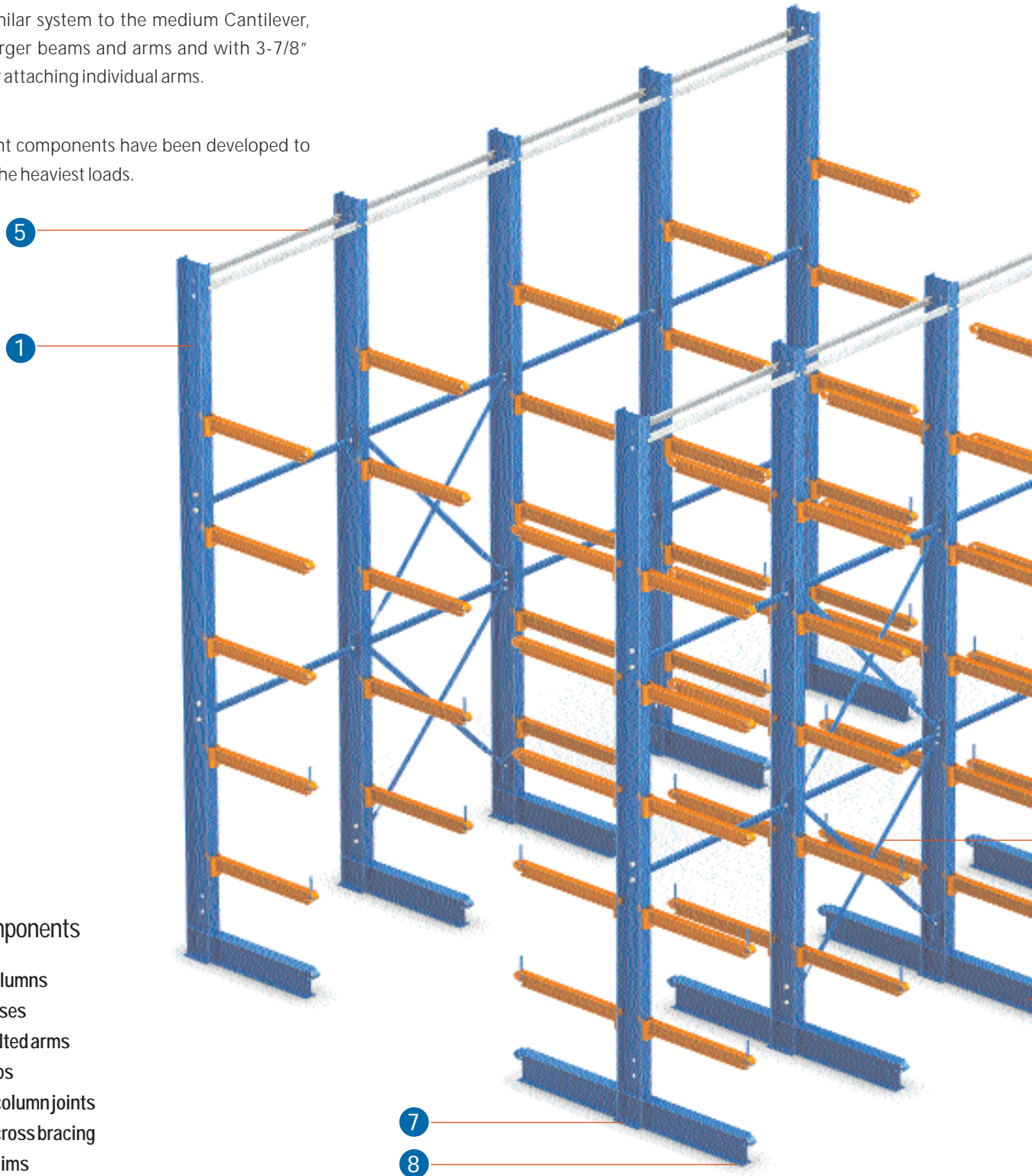

### Basic components

- 1) CTVH columns
- 2) CTVH bases
- 3) CTVH bolted arms
- 4) Arm stops
- 5) CTVMH column joints
- 6) CTVMH cross bracing
- 7) CTVH shims
- 8) Anchoring plates

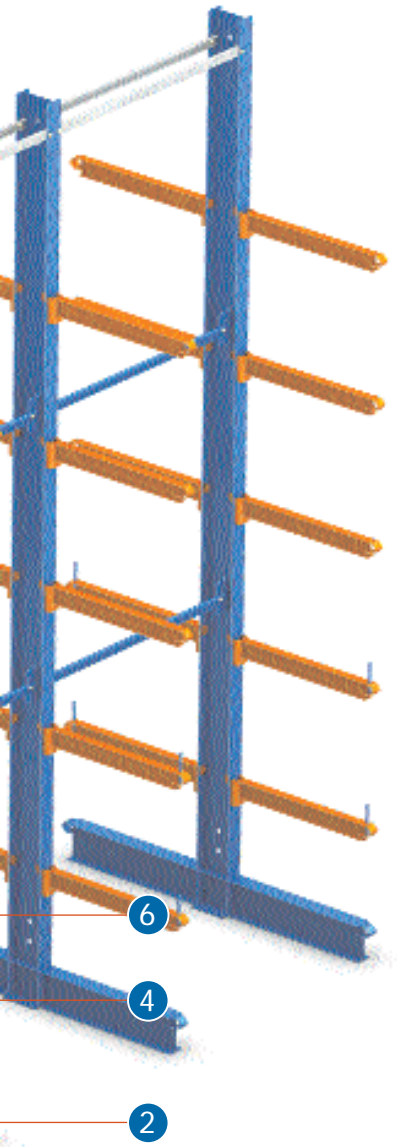

### Bolted Arms

These are generally used with very heavy loads or in situations where minimal movement of the arms is required. They consist of beams with a plate at one end for bolting them to the columns, while a curved part at the other end facilitates the placement of the loads, as well as serving to attach the stops.

The slight slope of the arms towards the column once assembled provides extra safety.

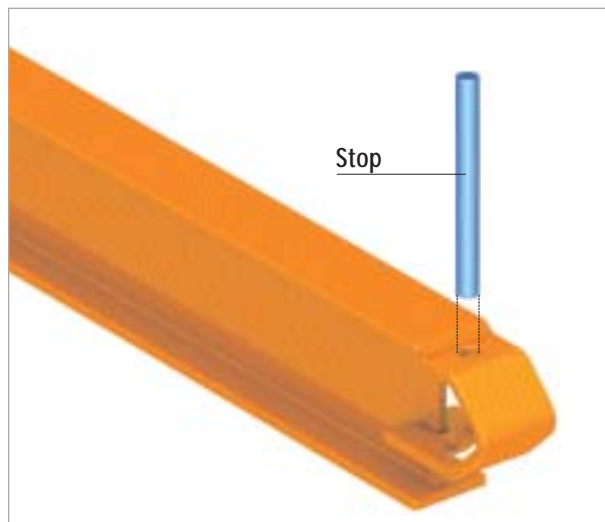

### Arm Stops

The stops consist of a round tube and a plastic protection plug which are inserted in the top hole on the supports and fit into the lower tab, thereby preventing loose goods from falling.

## Heavy Duty Cantilever

### Columns

These are W8" x13 bolted, W8" x15 bolted, W8" x18 bolted or W10" x19 bolted structural profiles, with slotted flanges for attaching the arms. At the bottom of the columns are support plates, reinforcements and holes for anchoring the bases.

The columns are generally made of one profile. If necessary, two profiles can be joined together, thereby considerably increasing their load-bearing capacity.

The slots on the columns are designed for both hooked and bolted arms to be at 3-15/16" intervals.

### Base Detail

The base is bolted to the column using an attachment plate.

At the other end, the curved stop attachment parts facilitate the placement of the loads.

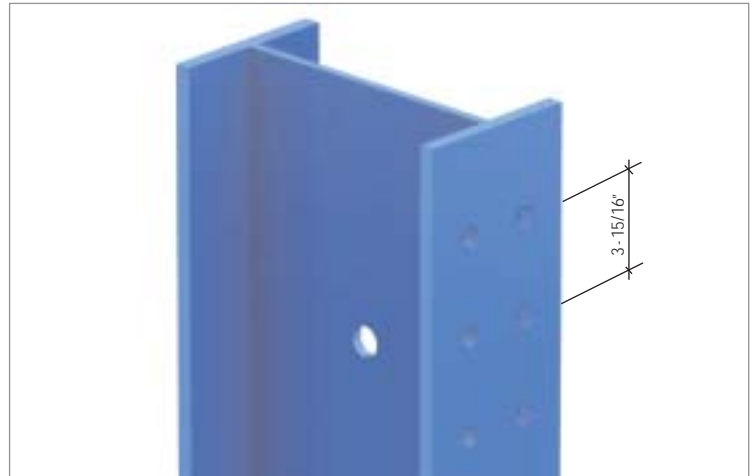

Single column



Double column

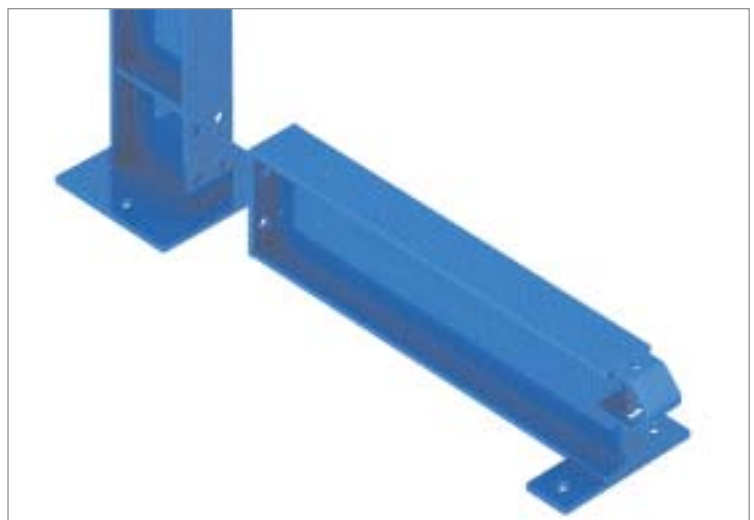

**CAPACITY (lbs) FOR STRUCTURAL CANTILEVER ARMS**

Column		L=Arm (inch)								
		20	24	30	36	40	48	56	64	100
W 8"x13	S 3"x5.7	1822	1516	1209	1004	901	746	635	549	190
	S 4"x7.7	1934	1608	1282	1242	1114	922	784	679	409
	S 6"x12.5	3300	2745	2188	1816	1629	1347	1144	990	591
W 8"x15	S 3"x5.7	1839	1530	1221	1014	910	753	641	556	251
	S 4"x7.7	2255	1876	1496	1242	1114	922	784	679	409
	S 6"x12.5	4467	3717	2966	2464	2212	1833	1560	1355	825
W 8"x18	S 3"x5.7	1927	1603	1279	1069	954	790	672	583	257
	S 4"x7.7	2670	2222	1773	1473	1322	1095	932	809	492
	S 6"x12.5	5072	4222	3370	2800	2515	2085	1777	1544	946
W 10"x19	S 3"x5.7	1875	1560	1245	1034	928	769	654	567	344
	S 4"x7.7	3235	2693	2149	1786	1604	1331	1134	986	605
	S 6"x12.5	7153	5956	4757	3656	3555	2952	2520	2194	1362

The evenly distributed load is calculated in lbs.

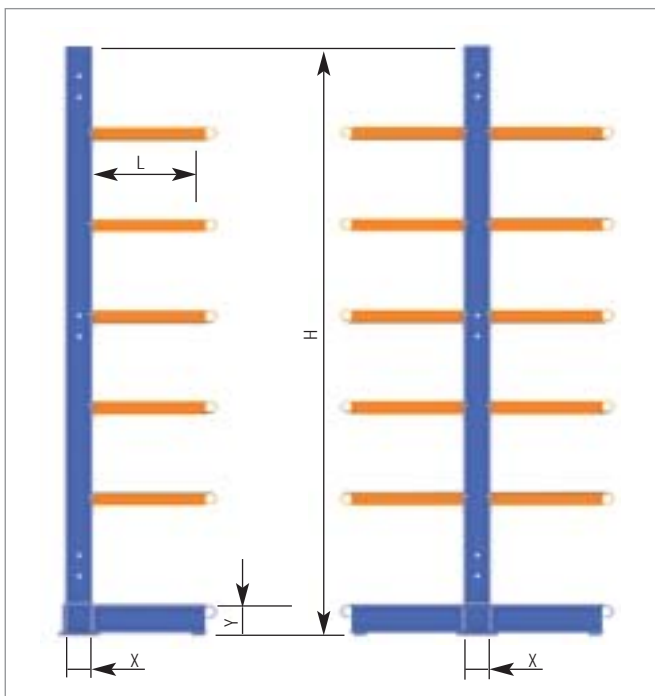
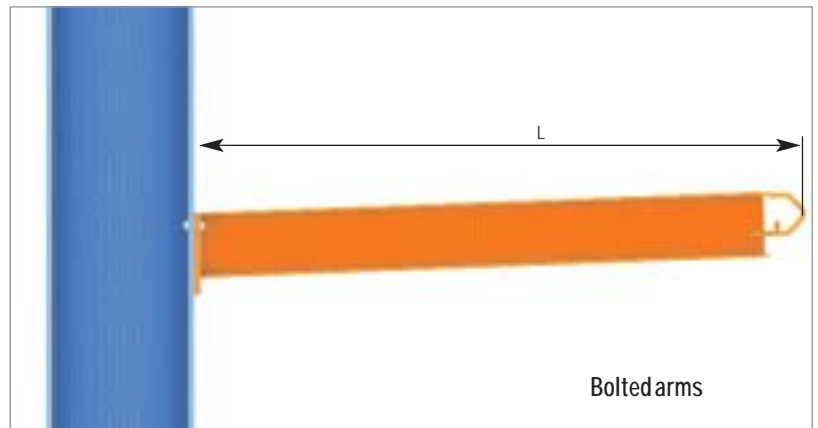

# Cantilever Racking

## CAPACITY PER COLUMN (load in lbs)

H= Column (ft)	L=Arm (inch)	SINGLE SIDE							DOUBLE SIDE								
		W8"x13		W8"x15		W8"x18		W10"x19	W8"x13		W8"x15		W8"x18		W10"x19		
8	20	15932		19004		19424		23808		31864		38008		38848		47616	
	24	14320		16960		16984		21004		28640		33920		33968		42008	
	30	12264		14252		14276		17840		24528		28504		28552		35680	
	36	10684		12280		12300		15488		21368		24560		24600		30976	
	40	9828		11232		11252		14232		19656		22464		22504		28464	
	48	8460		9584		9600		12228		16920		19168		19200		24456	
	56	7408		8336		8352		10700		14816		16672		16704		21400	
	64	6576		736		7376		9500		13152		14720		14752		19000	
100	4248		4707		4716		6192		8496		9414		9432		12384		
10	20	14980		17975		19405		23790		29960		35950		38810		47580	
	24	13470		16182		16960		20985		26940		32364		33920		41970	
	30	11595		13980		14250		17810		23190		27960		28500		35620	
	36	10090		12190		12265		15455		20180		24380		24530		30910	
	40	9280		11195		11215		14195		18560		22390		22430		28390	
	48	7975		9540		9555		12185		15950		19080		19110		24370	
	56	6975		8285		8305		10650		13950		16570		16610		21300	
	64	6175		7305		7320		9440		12350		14610		14640		18880	
100	3925		4615		4625		6105		7850		9230		9250		12210		
12	20	13951	14084	16863		19369		23772		27902	28168	33726		38738		47544	
	24	12551	12707	15190		16919		20964	21068	25102	25414	30380		33838		41928	42136
	30	10871	11050	13209		14196		17784		21742	22100	26418		28392		35568	
	36	9450	9661	11508		12201		15426		18900	19322	23016		24402		30852	
	40	8680	8912	10584	10813	11144		14160		17360	17824	21168	21626	22288		28320	
	48	7441	7712	9093	9365	9471		12144		14882	15424	18186	18730	18942		24288	
	56	6475	6793	7938	8255	8204		10602		12950	13586	15876	16510	16408		21204	
	64	5705	6066	7014	7376	7203		9384	9670	11410	12132	14028	14752	14406		18768	19340
100	3507	4065	4403	4959	4445		6012	6461	7014	8130	8806	9918	8890		12024	12922	
14	20	15216		18240		19352		23736	23862	30432	0	36480	0	38704	0	47472	47724
	24	13620	13844	16400		16896		20920	21068	27240	27688	32800	0	33792	0	41840	42136
	30	11406	11921	13794	14324	14168		17728	17918	22812	23842	27588	28648	28336	0	35456	35836
	36	9786	10413	11856	12375	12168		15350	15585	19572	20826	23712	24750	24336	0	30700	31170
	40	8928	9601	10824	11340	11112		14088	14338	17856	19202	21648	22680	22224	0	28176	28676
	48	7566	8303	9198	9711	9432		12056	12356	15132	16606	18396	19422	18864	0	24112	24712
	56	6543	7310	7962	8487	8152	8503	10504	10852	13086	14620	15924	16974	16304	17006	21008	21704
	64	5718	6525	6990	7532	7144	7547	9272	9670	11436	13050	13980	15064	14288	15094	18544	19340
100	3336	4371	4208	4973	4360	4983	5840	6461	6672	8742	8416	9946	8720	9966	11680	12922	
17	20	12840	15647	15510	18798	19320		23700	23862	25680	31294	31020	37596	38640	0	47400	47724
	24	11160	14095	13510	16939	16850	17046	20880	21068	22320	28190	27020	33878	33700	34092	41760	42136
	30	9300	12154	11280	14334	14110	14330	17680	17918	18600	24308	22560	28668	28220	28660	35360	35836
	36	7930	10618	9640	12375	12110	12396	15300	15585	15860	21236	19280	24750	24220	24792	30600	31170
	40	7190	9791	8770	11340	11040	11359	14020	14338	14380	19582	17540	22680	22080	22718	28040	28676
	48	6020	8468	7370	9711	9340	9728	11970	12356	12040	16936	14740	19422	18680	19456	23940	24712
	56	5120	7455	6310	8487	8050	8503	10400	10852	10240	14910	12620	16974	16100	17006	20800	21704
	64	4410	6655	5460	7532	7030	7547	9160	9670	8820	13310	10920	15064	14060	15094	18320	19340
100	2340	4460	3050	4973	4180	4983	5660	6461	4680	8920	6100	9946	8360	9966	11320	12922	
20	20	10611	15041	12825	18033	16569	19476	23463	23862	21222	30082	25650	36066	33138	38952	46926	47724
	24	9216	13551	11169	16263	14445	17046	20664	21068	18432	27102	22338	32526	28890	34092	41328	42136
	30	7668	11699	9315	14086	12192	14356	17496	17918	15336	23398	18630	28172	24384	28712	34992	35836
	36	6528	10221	7980	12317	10404	12396	15129	15585	13056	20442	15960	24634	20808	24792	30258	31170
	40	5904	9426	7224	11340	9456	11359	13944	14338	11808	18852	14448	22680	18912	22718	27888	28676
	48	4884	8152	6024	9711	7932	9728	11835	12356	9768	16304	12048	19422	15864	19456	23670	24712
	56	4104	7178	5100	8487	6768	8503	10272	10852	8208	14356	10200	16974	13536	17006	20544	21704
	64	3468	6407	4356	7532	5844	7547	8988	9670	6936	12814	8712	15064	11688	15094	17976	19340
100	1596	4292	2184	4973	3180	4983	5340	6461	3192	8584	4368	9946	6360	9966	10680	12922	
24	20	8701	13544	10538	16324	13640	19458	19426	23844	17402	27088	21076	32648	27280	38916	38852	47688
	24	7546	11838	9152	15188	11869	17026	17083	21048	15092	23676	18304	30376	23738	34052	34166	42096
	30	6237	10980	7601	13260	9889	14330	14432	17892	12474	21960	15202	26520	19778	28660	28864	35784
	36	5269	9600	6446	11638	8426	12364	12441	15552	10538	19200	12892	23276	16852	24728	24882	31104
	40	4752	8850	5830	10738	7645	11324	11374	14302	9504	17700	11660	21476	15290	22648	22748	28604
	48	3916	7648	4840	9290	6402	9686	9658	12314	7832	15296	9680	18580	12804	19372	19316	24628
	56	3267	6724	4081	8178	5445	8452	8338	10802	6534	13448	8162	16356	10890	16904	16676	21604
	64	2739	5992	3465	7296	4675	7490	7271	9612	5478	11984	6930	14592	9350	14980	14542	19224
100	1166	3964	1650	4856	2464	4894	4246	6372	2332	7928	3300	9712	4928	9788	8492	12744	

## Accessories

### Lift Truck Guides

The most suitable lift trucks for working with Cantilever racking are four-way side-loading lift trucks, which accept beam packages of up to 47- 1/4" in length.

These trucks require guide rails in the loading aisles in order to move around safely. The distance between the guides and loads, and the type of beam required, depend on the model of lift truck.

The required measurements for the aisles, which vary according to the machine, should be accounted for.

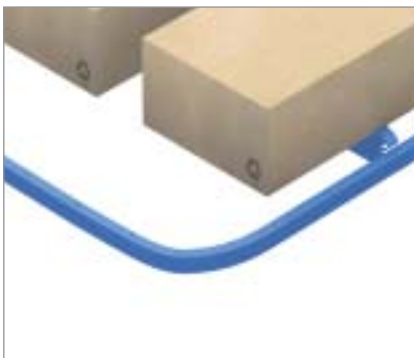
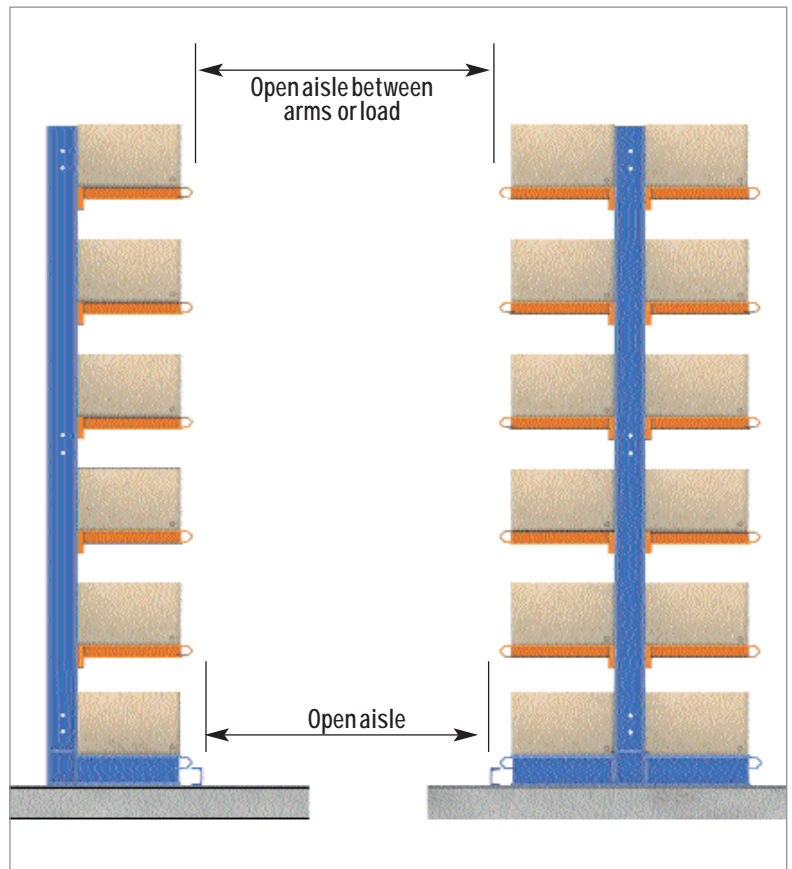

### Guide Entrances

At the start of each aisle, the guides require entrances to enable the lift trucks to enter correctly.

These entrances should be placed before the first package of goods stored.



### Top Tie Beams

When required, the system may be fitted with a top-beam joint to connect the columns across the top for greater stability.



### Load Safety Notices

These are plates providing information on the technical specifications of the installation. They are placed in visible areas at the ends of the installation.

## Cantilever Racking

### Outdoor Cantilever

Cantilever shelving is often installed outdoors.

In such cases, Mecalux provides all necessary accessories to protect stored goods from the weather, such as roofing, facades and canopies.

The diagrams on this page show two possible solutions.

### Basic Components

- 1) Complete Cantilever unit
- 2) Inclined frame or top-beams
- 3) Purlins
- 4) Apexroof

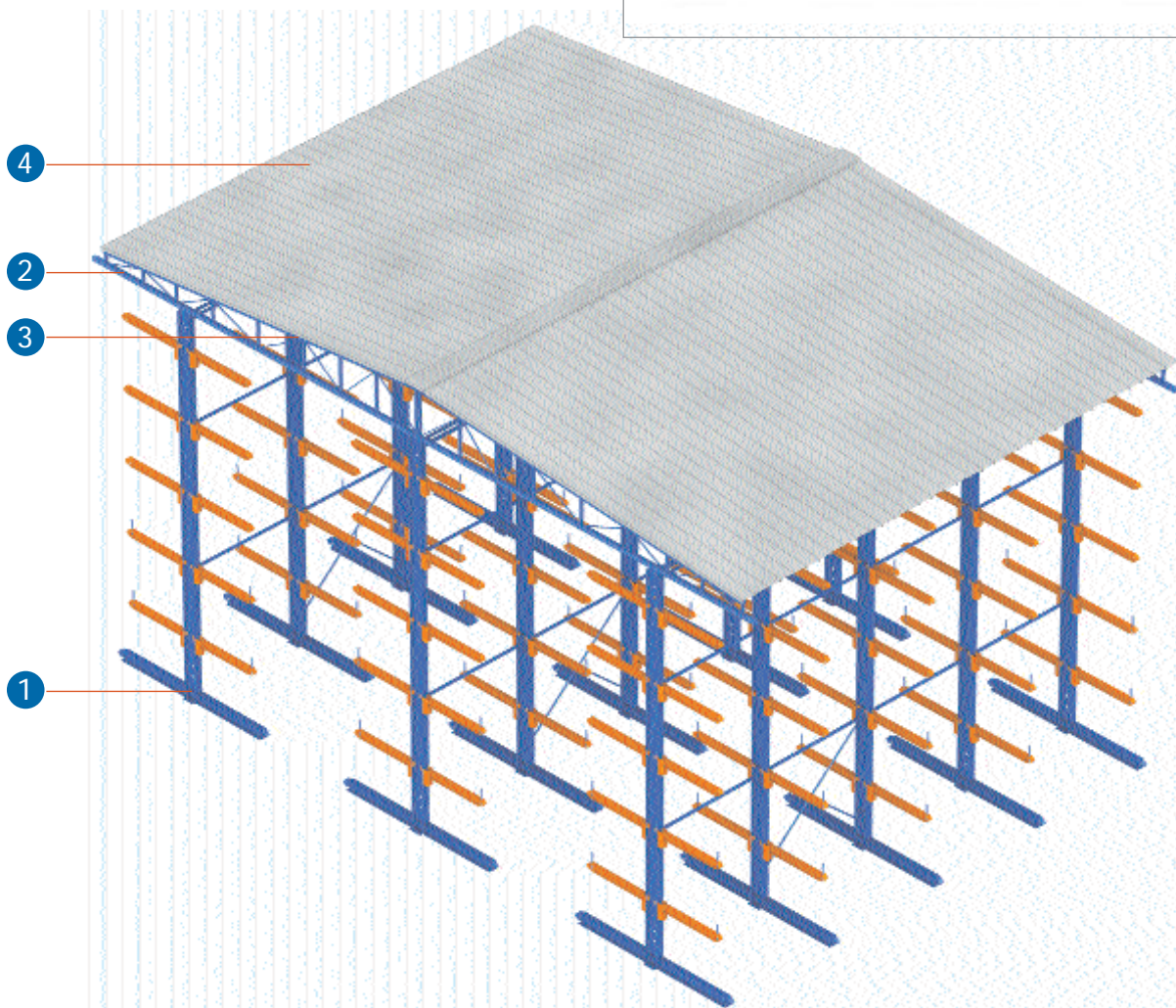
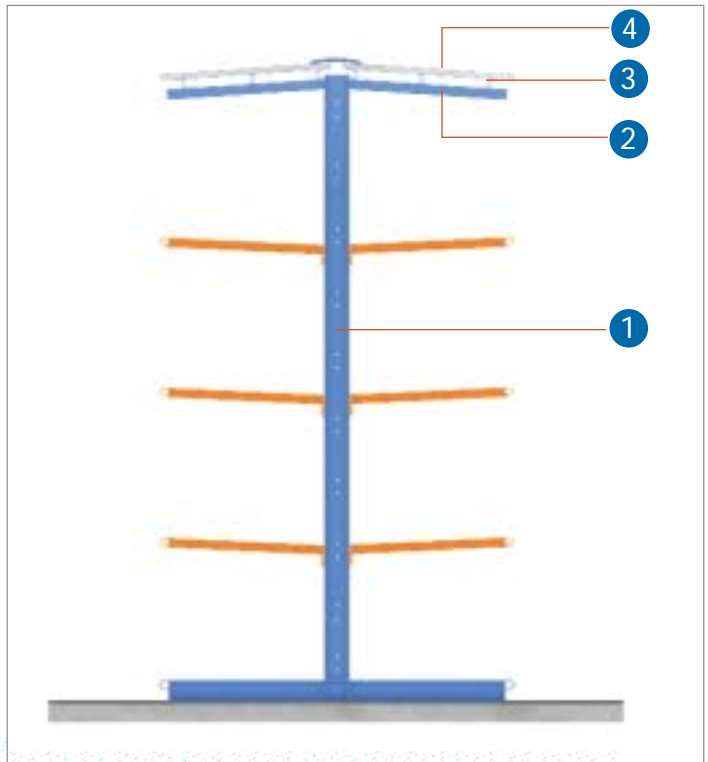

## Self-supporting Warehouses

Due to the high cost of traditional building, it may prove more economical to use the shelves as support for both the weight of stored products and the building loads (wind, snow, seismic loads etc.); to do this, the system requirements are calculated and A-frames, secondary beams, roof and walls are installed, creating a self-supporting structure.

